

WHELEN[®]

ENGINEERING COMPANY INC.

51 Winthrop Road
Chester, Connecticut 06412-0684
Phone: (860) 526-9504
Fax: (860) 526-4078
Internet: www.whelen.com
Sales e-mail: autosale@whelen.com
Canadian Sales e-mail: canadiansales@whelen.com
Customer Service e-mail: custserv@whelen.com

Installation Guide: Howler™ Siren Amplifier

DANGER! Sirens produce extremely loud emergency warning tones! Exposure to these tones without proper and adequate hearing protection, could cause ear damage and/or hearing loss! The Occupational Safety & Health Administration (www.osha.gov) provides information necessary to determine safe exposure times in Occupational Noise Exposure Section 1910.95. Until you have determined the safe exposure times for your specific application, operators and anyone else in the immediate vicinity should be required to wear an approved hearing protection device. **FAILURE TO FOLLOW THIS RECOMMENDATION COULD CAUSE HEARING LOSS!**

Warnings to Installers

Whelen's emergency vehicle warning devices must be properly mounted and wired in order to be effective and safe. Read and follow all of Whelen's written instructions when installing or using this device. Emergency vehicles are often operated under high speed stressful conditions which must be accounted for when installing all emergency warning devices. Controls should be placed within convenient reach of the operator so that they can operate the system without taking their eyes off the roadway. Emergency warning devices can require high electrical voltages and/or currents. Properly protect and use caution around live electrical connections. Grounding or shorting of electrical connections can cause high current arcing, which can cause personal injury and/or vehicle damage, including fire. Many electronic devices used in emergency vehicles can create or be affected by electromagnetic interference. Therefore, after installation of any electronic device it is necessary to test all electronic equipment simultaneously to insure that they operate free of interference from other components within the vehicle. Never power emergency warning equipment from the same circuit or share the same grounding circuit with radio communication equipment. All devices should be mounted in accordance with the manufacturer's instructions and securely fastened to vehicle elements of sufficient strength to withstand the forces applied to the device. Driver and/or passenger air bags (SRS) will affect the way equipment should be mounted. This device should be mounted by permanent installation and within the zones specified by the vehicle manufacturer, if any. Any device mounted in the deployment area of an air bag will damage or reduce the effectiveness of the air bag and may damage or dislodge the device. Installer must be sure that this device, its mounting hardware and electrical supply wiring does not interfere with the air bag or the SRS wiring or sensors. Mounting the unit inside the vehicle by a method other than permanent installation is not recommended as unit may become dislodged during swerving; sudden braking or collision. Failure to follow instructions can result in personal injury. Whelen assumes no liability for any loss resulting from the use of this warning device. **PROPER INSTALLATION COMBINED WITH OPERATOR TRAINING IN THE PROPER USE OF EMERGENCY WARNING DEVICES IS ESSENTIAL TO INSURE THE SAFETY OF EMERGENCY PERSONNEL AND THE PUBLIC.**

Warnings to Users

Whelen's emergency vehicle warning devices are intended to alert other operators and pedestrians to the presence and operation of emergency vehicles and personnel. However, the use of this or any other Whelen emergency warning device does not guarantee that you will have the right-of-way or that other drivers and pedestrians will properly heed an emergency warning signal. Never assume you have the right-of-way. It is your responsibility to proceed safely before entering an intersection, driving against traffic, responding at a high rate of speed, or walking on or around traffic lanes. Emergency vehicle warning devices should be tested on a daily basis to ensure that they operate properly. When in actual use, the operator must ensure that both visual and audible warnings are not blocked by vehicle components (i.e.: open trunks or compartment doors), people, vehicles, or other obstructions. It is the user's responsibility to understand and obey all laws regarding emergency warning devices. The user should be familiar with all applicable laws and regulations prior to the use of any emergency vehicle warning device. Whelen's audible warning devices are designed to project sound in a forward direction away from the vehicle occupants. However, because sustained periodic exposure to loud sounds can cause hearing loss, all audible warning devices should be installed and operated in accordance with the standards established by the National Fire Protection Association.

Safety First

This document provides all the necessary information to allow your Whelen product to be properly and safely installed. Before beginning the installation and/or operation of your new product, the installation technician and operator must read this manual completely. Important information is contained herein that could prevent serious injury or damage.

- Proper installation of this product requires the installer to have a good understanding of automotive electronics, systems and procedures.
- Whelen Engineering requires the use of waterproof butt splices and/or connectors if that connector could be exposed to moisture.
- Failure to use specified installation parts and/or hardware will void the product warranty.
- If mounting this product requires drilling holes, the installer **MUST** be sure that no vehicle components or other vital parts could be damaged by the drilling process. Check both sides of the mounting surface before drilling begins. Also de-burr the holes and remove any metal shards or remnants. Install grommets into all wire passage holes.
- If this manual states that this product may be mounted with suction cups, magnets, tape or Velcro®, clean the mounting surface with a 50/50 mix of isopropyl alcohol and water and dry thoroughly.
- Do not install this product or route any wires in the deployment area of your air bag. Equipment mounted or located in the air bag deployment area will damage or reduce the effectiveness of the air bag, or become a projectile that could cause serious personal injury or death. Refer to your vehicle owner's manual for the air bag deployment area. The User/Installer assumes full responsibility to determine proper mounting location, based on providing ultimate safety to all passengers inside the vehicle.
- For this product to operate at optimum efficiency, a good electrical connection to chassis ground must be made. The recommended procedure requires the product ground wire to be connected directly to the NEGATIVE (-) battery post (this does not include products that use cigar power cords).
- If this product uses a remote device for activation or control, make sure that this device is located in an area that allows both the vehicle and the device to be operated safely in any driving condition.
- It is recommended that these instructions be stored in a safe place and referred to when performing maintenance and/or reinstallation of this product.
- **FAILURE TO FOLLOW THESE SAFETY PRECAUTIONS AND INSTRUCTIONS COULD RESULT IN DAMAGE TO THE PRODUCT OR VEHICLE AND/OR SERIOUS INJURY TO YOU AND YOUR PASSENGERS!**

**ACTIVATION OF THIS
SIREN MAY DAMAGE
UNPROTECTED EARS!**



CAUTION
Loud siren noise can cause hearing damage and/or loss. Refer to OSHA Section 1910.95 prior to putting ANY siren into service!

IMPORTANT! READ THESE WARNINGS BEFORE CONTINUING!

The Howler™ Supplemental Siren was designed for use in high-risk areas such as an intersection. It is not intended to be, nor should be operated as, a replacement or alternative to the vehicle's primary siren.

The low-frequency tones of the Howler demonstrate significantly different audio characteristics as compared to those of a traditional higher-frequency siren. While the low-frequency tones are better able to penetrate other vehicles, thus alerting drivers to the presence of the responding emergency vehicle, these tones may also penetrate into the responding vehicle itself. This could potentially expose the operator to increased noise levels.

To help eliminate overexposure, the Howler siren has been designed with a built-in timing circuit. The Occupational Safety & Health Administration (OSHA) (www.osha.gov) provides information necessary to determine safe exposure times in Noise and Hearing Conservation, Section 1910.95 (Occupational Noise Exposure). Until you have determined the safe exposure times for your specific application, this siren should be configured for the minimum operating time and operators should be required to use an approved hearing protection device. **FAILURE TO FOLLOW THIS RECOMMENDATION COULD CAUSE HEARING LOSS!**

Mounting:

1. Locate a suitable mounting location. The vertical wall between the trunk and the passenger compartment is often a good choice and is the method described in this manual.
2. Be sure that the remote amplifier fits properly and does not interfere with any parts of the trunk lid or seat back.
3. Position the remote amplifier onto the mounting location. Using an awl or other suitable tool, scribe the mounting surface where the mounting holes are to be drilled.

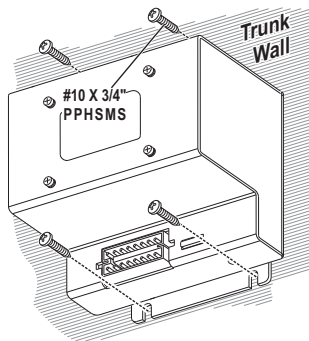

CAUTION! Mounting the siren will require drilling. It is absolutely necessary to make sure that no other vehicle components could be damaged while drilling. If any vehicle component could suffer any potential harm, select a different mounting location.

4. Carefully drill the mounting holes using a #16 drill bit.
5. Using the supplied #10 x 3/4" sheet metal screws, secure the remote amplifier to the vertical trunk wall.

Wiring:

Power:

WARNING! All customer supplied wires that connect to the positive terminal of the battery must be sized to supply at least 125% of the maximum operating current and FUSED at the battery to carry that load. DO NOT USE CIRCUIT BREAKERS WITH THIS PRODUCT!

1. Using appropriately sized wire, extend the two (2) RED wires along the factory wiring harness to the POSITIVE +12VDC battery terminal.
2. Connect the RED wires to one end of a user supplied fuse block. *Do not connect this fuse block to the battery yet.*
3. Using appropriately sized wire, extend the two (2) BLACK wires along the factory wiring harness to the NEGATIVE battery terminal.

Control Switches:

Install two Normally Open Momentary Switches in an area that can be safely accessed by the operator. One switch will serve as the Activation Switch. The other will serve as the Cancellation Switch. **Refer to the Air Bag Warning on page 1 before extending any wires into the interior of the vehicle!**

Activation Switch

1. **Positive Activation:** Extend the WHT/BRN and RED/WHT wires to the Activation Switch (See wiring diagram).
2. Connect the WHT/BRN wire to one side of the Activation Switch and the RED/WHT wire to the other side of this switch.
3. **Negative Activation:** Extend the BLUE wire to the activation switch and connect the other side to ground (See wiring diagram).

Cancellation Switch

1. Extend the GRN wire to the Cancellation Switch.
2. Connect the GRN wire to one side of this switch. The other side of this switch must be connected to Chassis Ground.

or

1. Extend the WHT/GRN wire to the Cancellation Switch.
2. Connect the WHT/GRN wire to one side of this switch. Extend a wire from the other side of this switch and splice it onto the RED/WHT wire.

Speakers:

1. Extend the ORANGE, YELLOW and BROWN wires along the factory wiring harness towards your speakers.
2. Connect the YELLOW wire to the POSITIVE (+) terminal on speaker #1. Connect the ORANGE wire to the POSITIVE (+) terminal on speakers #2.
3. Connect the BROWN wire to the NEGATIVE (-) terminal on both speakers.

Primary Siren Input:

1. Extend the WHT/ORG and WHT/YEL wires to the vehicle's primary siren speaker.
2. Splice the WHT/ORG wire onto the positive terminal of the primary siren speaker.
3. Splice the WHT/YEL wire onto the negative terminal of the primary siren speaker.

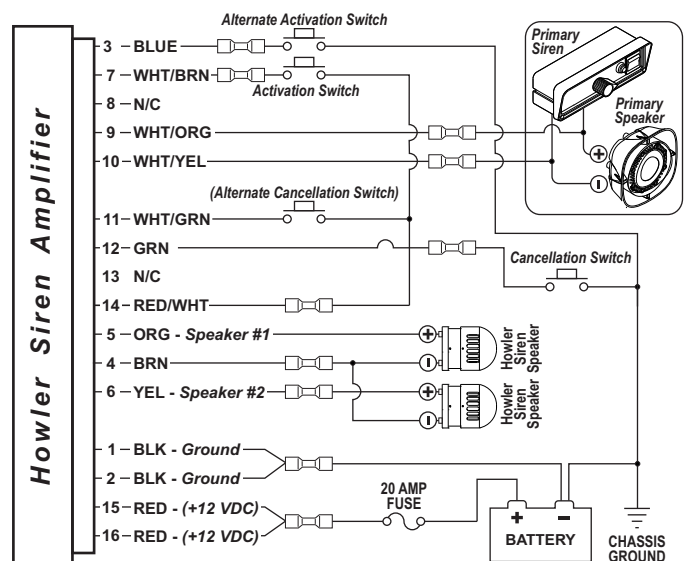

Configuring the Howler™:

There are two important operational characteristics of the Howler that can be configured; Tone Style and Tone Duration. The Scan-Lock™ button is used to place the Howler in configuration mode, as well as to select the desired style.

The Scan-Lock button is located as shown and can be activated with a pen or similar object.

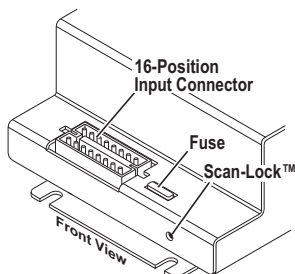

REAR VIEW of Amplifier

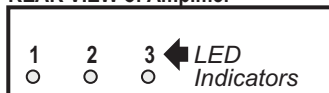

Three LEDs, located on the rear of the Howler amplifier, provide a visual indication of the currently selected style during the configuration process.

The configuration procedure used to configure Tone Style is different from the one used to configure Tone Duration. The procedure for each operational characteristic is outlined below.

Configuring Tone Style

The Howler siren system is designed to enhance the effectiveness of the vehicles siren system. This is achieved due to the Howler's ability to match the higher frequency tonal signatures of the primary siren with the penetrating characteristics of low frequency tones. The Howler can do this in one of four styles:

- It can generate tones that are 1/4 of the frequency of the primary siren tone (the default style).
- It can generate tones that are 1/2 of the frequency of the primary siren tone (recommended if Hi/Low is the primary siren tone).
- It can generate tones that are a combination of 1/4 and 1/2 of the frequency of the primary siren tone.
- It can generate tones that are the primary siren tone divided by 4-1/2.

This section will outline how to select the desired tone style.

1. **Disconnect** the primary siren input wires (WHT/ORG & WHT/YEL) from the primary siren speaker.
2. **Press and hold** the Scan-Lock button. Now **press and release** the Activation Switch.
3. **Immediately release** the Scan-Lock button. The Howler is now in Configuration Mode.

Table 1: Tone Style

LED 1	LED 2	LED 3	TONE STYLE
On	Off	Off	1/4 primary siren tone frequency (default)
Off	On	Off	1/2 primary siren tone frequency
On	On	Off	1/4 & 1/2 primary siren tone frequency
Off	Off	On	Primary siren tone frequency divided by 4-1/2

4. Using the Scan-Lock button, cycle through the three different tone styles. The currently selected style can be identified by the LED indicators. Refer to Table 1 for LED display information.
5. When the desired Tone Style has been selected, **press and release** the Activation Switch to exit the configuration mode.
6. **Reconnect** the Primary Siren Input wires to the primary siren speaker.

Configuring Tone Duration

IMPORTANT! The Howler siren system is to be used for brief periods of supplemental use only. Continuous, prolonged use of a low frequency siren could expose the operator to unsafe noise levels. If the Howler continues to broadcast tones for a length of time that exceeds the configured duration, manually turn the Howler off and contact Whelen customer support.

The following section will outline how to select the desired Tone Duration.

1. **Disconnect** the Primary Siren Input wires (WHT/ORG & WHT/YEL) from the primary siren speaker.
2. **Press and hold** the Activation Switch.
3. Using the Scan-Lock button, cycle through the eight different Tone Duration times. The currently selected time can be identified by the LED indicators. Refer to Table 2 for LED display information.

Table 2: Tone Duration

LED 1	LED 2	LED 3	TONE DURATION
Off	Off	Off	7.5 Seconds (default)
On	Off	Off	15 Seconds
Off	On	Off	22.5 Seconds
On	On	Off	30 Seconds
Off	Off	On	37.5 Seconds
On	Off	On	45 Seconds
Off	On	On	52.5 Seconds
On	On	On	60 Seconds

4. When the desired Tone Duration has been selected, release the Activation Switch to exit the configuration mode.
5. **Reconnect** the Primary Siren Input wires to the primary siren speaker.

Restoring Factory Defaults

1. **Disconnect** the Primary Siren Input wires (WHT/ORG & WHT/YEL) from the primary siren speaker.
2. **Press and hold** the Scan-Lock button. Now **press and release** the Activation Switch.
3. **Continue to hold** the Scan-Lock button until all three LED indicators are flashing.
4. **Release** the Scan-Lock button. Now **press and release** the Activation Switch to exit the configuration mode.

Siren Operation:

Reminder! As stated previously, the Howler is designed to operate as a supplement to the primary siren. To this end, the Howler will not operate unless the primary siren is actively generating a siren tone.

To activate the Howler™ siren, press the Activation Switch while the primary siren is generating a tone. The Howler will match the primary siren according to the Tone Style configuration settings. Once activated, the Howler will produce tones for a period of time determined by the Tone Duration configuration settings. When that duration has been reached, the Howler will automatically stop.

To cancel the Howler siren before the Tone Duration time period is completed, press the activation switch a second time or press the cancellation button.